



# FOCAL POINT

STORIES TO SHARE WITH MAZDA OWNERS AND CUSTOMERS



## A DISTINCTLY MAZDA APPROACH TO ELECTRIFICATION

### MAZDA'S VISION FOR THE FUTURE

Mazda is dedicated to creating a range of technologies that meet the needs of the future while enriching the lives of people and society.

BY 2030, MAZDA EXPECTS

**100% OF MAZDA VEHICLES**

WILL INTEGRATE SOME LEVEL OF ELECTRIFICATION

*"Mazda is preparing for the fast-changing U.S. market demands by taking a multi-solution approach to electrification. The battery-powered MX-30 will begin the introduction of additional electrified models, including a series plug-in hybrid with a rotary generator for MX-30, a plug-in hybrid for our new large platform, and a traditional hybrid for our new American-made crossover. While these powertrains will be optimized for their platforms, Mazda fans can expect great driving dynamics and beautiful design across all models."*

– Jeff Guyton, President and CEO of Mazda North American Operations

### A DEEPER LOOK

Mazda's new technology and product development policy, based on the Sustainable Zoom-Zoom 2030 vision, looks to the future of electrification and sustainability. [Learn more about Mazda's upcoming technology and plans for carbon neutrality on the Mazda Newsroom.](#)

### THE IMPORTANCE OF MAZDA'S FIRST ALL-ELECTRIC VEHICLE

MX-30 EV shares everything that our customers know and love about Mazda — now in an EV. But MX-30 EV is much more than just a new vehicle in the Mazda family.



As Mazda's first battery-electric vehicle, MX-30 EV is a milestone step in Mazda's multi-solution electrification strategy and will continue to raise awareness of and appreciation for Mazda's efforts in supporting the environment.



MX-30 EV stays true to Mazda's core philosophies and is designed around the driver — demonstrating that the driving experience does not need to be compromised when environmentalism is a focus.



MX-30 EV will help set a strong foundation for future expansion of Mazda's electrified lineup, including the exciting introduction of the 2023 MX-30 series plug-in hybrid with a rotary generator.



MAZDA SMART CARDS  
ELECTRIFICATION BASICS



Scan this code to access the **Why MX-30, Why Now** video.

Note: you will be directed to an interactive version of Focal Point. Select the menu icon on the top right to navigate to the video.



# ALL-NEW, ALL-ELECTRIC MAZDA MX-30 EV

## AN ELECTRIC VEHICLE DESIGNED AROUND THE DRIVER

In contrast to many conventional battery-electric vehicles that remove the human element in favor of a high-tech, ultramodern approach, the all-new Mazda MX-30 EV stays true to core brand philosophies — creating Mazda-unique value through an engaging, natural and deeply human-centric electric-vehicle experience.



### DISTINCTIVE DESIGN

*Pushes the boundaries of Kodo design to offer unique appeal that is distinctly Mazda.*



### ENGAGING AND NATURAL DRIVING EXPERIENCE

*Translates Mazda's Jinba-Ittai driving experience and connection to an electric vehicle.*



### SUSTAINABLE MATERIALS & WELL-CRAFTED INTERIOR

*Creates a sense of airiness and openness — it's a place you want to spend time.*



### PEACE OF MIND

*Supports the driver in a comfortable, confident drive that enhances the pure joy of driving.*



MAZDA SMART CARDS  
INTRODUCING MAZDA MX-30 EV



Scan this code to access the **MX-30: Distinctly Mazda, Now Electrified** video.

Note: you will be directed to an interactive version of Focal Point. Select the menu icon on the top right to navigate to the video.

### A DEEPER LOOK

The "MX" prefix is reserved for only the most innovative Mazda vehicles and concepts — those that create new value and challenge convention, such as the MX-5 Miata. Now, as the first fully electric Mazda, the MX-30 EV receives the coveted "MX" designation. [Learn more about the fourth-generation Mazda MX-5 Miata and its creation.](#)



#### 2021 WORLD CAR AWARDS

Top 10 Finalist: World Car of the Year

Top 3 Finalist: World Car Design of the Year



#### 2020 RED DOT AWARD

Car Design

### WHAT'S BEING SAID ABOUT MX-30 EV

*"Those who gripe that all electric vehicles are starting to look the same and follow the same specs should probably take a good look at the Mazda MX-30." – [Green Car Reports](#)*

*"... the 2022 Mazda MX-30's elegant styling and compact nature are sure to help it stand out in a growing field of EVs." – [Edmunds](#)*

*"The MX-30 sounds like a distinctly Mazda approach to electric vehicles, emphasizing driving character and later reintroducing the automaker's redesigned rotary engine." – [Consumer Reports](#)*



# ALL-NEW MAZDA MX-30 EV: TOP STORIES TO SHARE

## DISTINCTIVE DESIGN

MX-30 EV's "Human Modern" concept which pushes the boundaries of Kodo design to create a vehicle that is modern, expressive and familiar — and distinctly Mazda.



Scan this code to access the **Distinctive Design** video.

Note: you will be directed to an interactive version of Focal Point. Select the menu icon on the top right to navigate to the video.

- 1** Single, solid exterior conveys strength, simplicity and beauty
- 2** Deeply sculpted lamp design expresses energy and intent
- 3** Minimal grille evokes a sense of ease and approachability
- 4** Available three-tone exterior color option accentuates the modern design



## FREESTYLE DOORS

MX-30 EV features iconic freestyle doors that open from the center outward, helping to achieve a sense of openness and freedom. MX-30 EV's freestyle doors open wide for access to the rear seats, enabling natural entry and exit.

## A DEEPER LOOK

Mazda's rotary-powered RX-8 sports car marked Mazda's first application of freestyle doors. Including this prominent design feature on MX-30 EV is particularly fitting, considering the scheduled debut of the MX-30 series plug-in hybrid with rotary generator. While the rotary generator will function differently than the rotary engine in the RX-8, it's just more evidence of Mazda's dedication to innovative solutions and continuous improvement. [Visit Inside Mazda to learn more about the RX-8 and the history of Mazda's rotary technology.](#)

## OPEN, AIRY AMBIENCE

MX-30 EV's freestyle doors open to reveal an interior that is open, airy, calm and comfortable, with modern interior color themes that reflect the unique character of each owner.



Black with Pure White leatherette gives a feeling of modern confidence.



Black with Vintage Brown leatherette has an industrial vintage tone.





# ALL-NEW MAZDA MX-30 EV: TOP STORIES TO SHARE

## SUSTAINABLE MATERIALS & WELL-CRAFTED INTERIOR

MX-30 EV brings together high-quality craftsmanship, select materials and innovative technology to create an artisan and premium EV offering.



Scan this code to access the Sustainable Materials & Well-Crafted Interior video.

Note: you will be directed to an interactive version of Focal Point. Select the menu icon on the top right to navigate to the video.

## NATURAL, MAZDA-UNIQUE MATERIALS

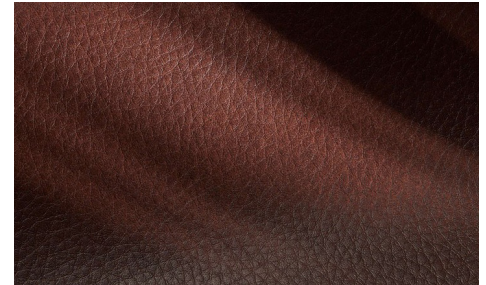
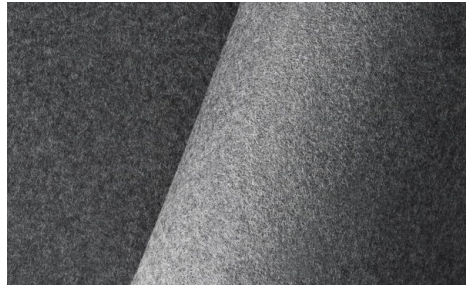

### HERITAGE CORK

- Natural material that comes from sustainably forested trees
- Deeply rooted in Mazda's origins as a manufacturer of cork products
- Creates a distinctly Mazda look that fuses style, function and heritage

### RECYCLED MATERIALS

- Exclusive fabric made using recycled plastic (PET) bottles is located on the door panels and creates an open, airy look
- Texture inspired by handmade Japanese *washi* paper
- Additionally, some seat materials use approximately 20% recycled threads

### PREMIUM VINTAGE LEATHERETTE

- Available faux leather printed with a deeply expressive vintage leather pattern
- Creates a sense of depth and texture that is pleasant to the touch
- No organic solvents used in the production process, lowering overall environmental impact

## A DEEPER LOOK

From cork that pays tribute to Mazda's heritage, to intricate fabric textures inspired by traditional Japanese *washi* paper, the history and craftsmanship behind MX-30 EV's unique materials run deep. [Visit Mazda Stories for more on MX-30's unique materials.](#)

## A SENSE OF CONNECTION



### FLOATING CONSOLE

- Fuses modern design and functionality
- Unique cut-out section strengthens the sense of connection between driver and passenger
- Useful storage space below; two cupholders seamlessly integrated behind the shifter and Commander control



### CLIMATE CONTROL DISPLAY

- New 7-inch touchscreen climate control display at front of floating console
- Simple layout and audible feedback reduce the need to look away from the road
- Buttons along the bezel also facilitate safe operation



# ALL-NEW MAZDA MX-30 EV: TOP STORIES TO SHARE

## DRIVING EXPERIENCE

Mazda made the most of MX-30 EV's unique qualities and characteristics as an electric vehicle, seeking to deepen the *Jinba-Ittai* connection between driver and vehicle to create an engaging driving experience of pure joy.



Scan this code to access the **Engaging, Natural Driving Experience** video.

Note: you will be directed to an interactive version of Focal Point. Select the menu icon on the top right to navigate to the video.

**Charge Port** – Allows the battery to be charged at home or at a public charging station.

**AC Onboard Charger** – Component that converts AC power from an external source into DC power used to charge the battery.

**Battery Pack** – Located under the floor. By mounting the battery modules close together, cooled by a thin refrigerant cooling system, the whole battery pack takes up a minimal amount of space.

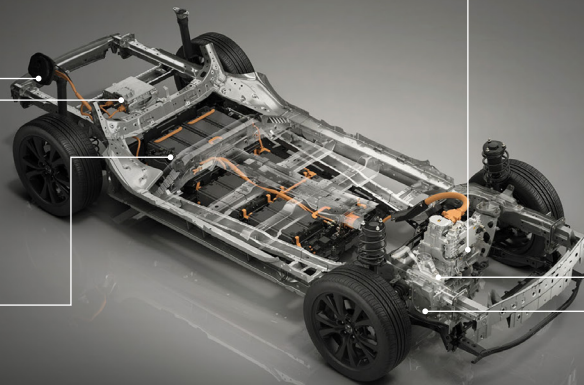

**DC-DC Converter** – Converts power from the high-voltage battery to 12 volts for MX-30 EV's 12-volt systems and accessories.

**Inverter** – Converts the electrical current from the battery to the correct voltage and uses it to power the motor.

**Electric Motor** – Integrated into a single high-voltage unit mounted toward the front of the vehicle.

## ELECTRIC G-VECTORING CONTROL PLUS

An evolution of Mazda's G-Vectoring Control Plus, e-GVC Plus delivers precise, natural steering and handling by leveraging the immediate response of the electric motor to shift weight between tires in response to the driver's steering input.

## STEERING-WHEEL PADDLES

Unlike many other electric vehicles, which require drivers to reach to the center console or display screen to adjust settings, MX-30 EV's steering-wheel paddles allow the driver to quickly adjust torque characteristics and regenerative braking strength on demand — two levels up and down from the default level — without taking their hands off the wheel.

## EV SOUNDS

Pleasant sounds connect the driver to the vehicle when the accelerator is pressed. It provides audible feedback in sync with the driver's input so they can enjoy intuitive control and feel more at home behind the wheel of an EV.



## THE APPROPRIATE BATTERY SIZE

Mazda aims to reduce the environmental footprint of its vehicles across the entire lifecycle — from producing raw materials, to driving the vehicle, all the way to end-of-life disposal. That's why Mazda chose to use a smaller battery pack in the MX-30 EV. This appropriate battery size helps achieve Mazda's environmental goal while empowering MX-30 EV owners in their unique lifestyle.





# ALL-NEW MAZDA MX-30 EV: TOP STORIES TO SHARE

## PEACE OF MIND

Like the entire Mazda lineup, MX-30 EV does not compromise on safety. MX-30 EV offers enhanced active and passive safety technologies designed to further support the driver and help them feel confident and stress-free on the road.



Scan this code to access the Peace of Mind video.

Note: you will be directed to an interactive version of Focal Point. Select the menu icon on the top right to navigate to the video.

## ENHANCED i-ACTIVSENSE® FEATURES



### FRONT CROSS TRAFFIC ALERT

When travelling at speeds below 6 miles per hour, this system produces an audible and visual alert to warn the driver when the front-facing camera detects objects approaching from the front left or right side of the vehicle at speeds above 3 miles per hour.

### BLIND SPOT ASSIST

Enhances Blind Spot Monitoring by providing steering assist to help keep the vehicle in its own lane if the driver attempts to change lanes while another vehicle is detected in the blind spot.

### DRIVER MONITOR

Provides a visual and audible alert to suggest taking a break when the driver monitoring camera, located in the Mazda Connect™ infotainment display housing, recognizes changes on the driver's face that could suggest sleepiness or fatigue while driving.

*For more on these and other safety and driver-assist features, visit the MX-30 EV Owner's Manual.*

## PASSIVE SAFETY

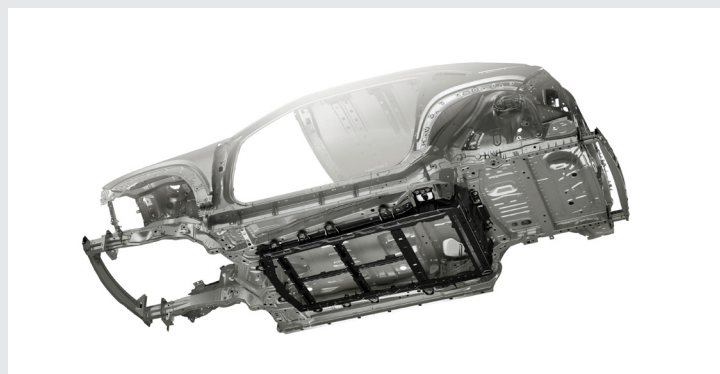

### LIGHTWEIGHT, HIGH-RIGIDITY BODY

- Uses a large amount of ultra-high-tensile steel
- Integrates high-efficiency shock-absorbing structures in each section of the body
- Hot-stamped material reinforcements placed vertically inside the rear door, plus reinforced hinges and side sills

### BATTERY SAFETY

- High-voltage battery isolated in robust protective structure
- Battery pack structure uses strong frame and covering made of high-strength materials
- Includes a power shutoff system in the event of a collision

# THE MX-30 EV OWNERSHIP EXPERIENCE

Mazda is committed to providing peace of mind and convenience across the entire electric-vehicle ownership experience. This includes a variety of programs and features that MX-30 EV owners are sure to appreciate.

## MX-30 ELITE ACCESS LOANER PROGRAM

For the first three years of ownership, MX-30 EV owners are eligible to access the MX-30 Elite Access Loaner Program fleet for 10 calendar days per year. This is a compelling benefit for MX-30 EV owners who enjoy road trips or take extended drives. It also allows MX-30 EV owners to experience and enjoy other Mazda vehicles in the lineup.



*\*Program subject to change*



## MAZDA CONNECTED SERVICES: ENHANCED FOR MX-30 EV OWNERS

Standard on all models, enhanced Connected Services features make life with MX-30 EV even more convenient. With a complimentary three-year subscription, owners can remotely control and monitor their MX-30 EV— all through the MyMazda app.

In addition to standard Connected Services features such as in-car Wi-Fi, remote door locks, vehicle finder and vehicle health reports, a variety of exclusive MyMazda app features enhance the electric ownership experience.

EXCLUSIVE FEATURES FOR EV OWNERS	
<b>REMOTE</b> When plugged in, remotely start or stop the charging process.	<b>CLIMATE</b> Adjust the climate controls while charging to preserve battery.
<b>STATUS</b> Check MX-30 EV's current battery status and driving range.	<b>SEARCH</b> Search charging stations and their availability status for easy navigation.



## MAZDA + CHARGEPOINT PARTNERSHIP

ChargePoint is one of the world's leading EV charging networks. Mazda has partnered with ChargePoint to offer convenient solutions for MX-30 EV owners and provide the best electric-vehicle ownership experience, including:

- Convenient ChargePoint app to streamline the public-charging process
- Driver's Kit provided at Delivery with essential information on how to enroll for ChargePoint services
- ChargePoint credit received with the purchase of a new MX-30 EV that can be used for public charging at ChargePoint stations, or toward the purchase of an in-home Level 2 charger directly from ChargePoint

*\*This incentive subject to change. Check with your District Manager or Dealer Management for the latest incentives*



[Visit the ChargePoint website to learn more.](#)



# MX-30 EV PACKAGES & KEY FEATURES

MX-30 EV offers a wide range of features and content for EV buyers, offering value above and beyond others in the segment.



<b>MX-30 EV</b>	<b>MX-30 EV PREMIUM PLUS</b> <i>In addition to MX-30 EV standard equipment</i>
<b>PERFORMANCE</b>	
<ul style="list-style-type: none"> <li>e-Skyactiv</li> <li>35.5 kWh lithium-ion battery</li> <li>Maximum power output of 107 kW (143 horsepower)</li> <li>Maximum torque of 270 Nm (200 lb-ft)</li> </ul>	
<b>EXTERIOR</b>	
<ul style="list-style-type: none"> <li>18" alloy wheels with Silver Finish</li> <li>P215/55R18 tires</li> <li>LED daytime running lights</li> <li>Front and rear LED signature illumination headlights</li> <li>Auto on/off headlights</li> <li>Heated, power-folding exterior mirrors with memory positioning</li> <li>Rain-sensing windshield wipers</li> </ul>	<ul style="list-style-type: none"> <li>18" alloy wheels with Bright Finish</li> <li>Auto-dimming exterior mirror (driver's side)</li> <li>Side-mirror turn lamps</li> <li>Mazda Advanced Keyless Entry</li> </ul>
<b>INTERIOR</b>	
<ul style="list-style-type: none"> <li>8.8-inch Mazda Connect™ display</li> <li>Mazda Connected Services</li> <li>Apple CarPlay® &amp; Android Auto™</li> <li>USB audio input (2)</li> <li>8-speaker audio system</li> <li>Active Driving Display</li> <li>Frameless auto-dimming interior mirror</li> <li>Leather-wrapped steering wheel &amp; shift knob</li> <li>8-way power driver's seat with power lumbar support and memory</li> <li>Heated front seats</li> <li>Power sliding-glass moonroof</li> </ul>	<ul style="list-style-type: none"> <li>Frameless auto-dimming interior mirror with HomeLink®</li> <li>SiriusXM® Satellite Radio w/3-month trial (excluding AK &amp; HI)</li> <li>Bose® Premium Audio with 12 speakers</li> <li>Heated steering wheel</li> <li>Cargo area light</li> </ul>
<b>SAFETY &amp; SECURITY</b>	
<ul style="list-style-type: none"> <li>Adaptive Front-Lighting System (AFS)</li> <li>Driver Attention Alert (DAA)</li> <li>High Beam Control (HBC)</li> <li>Lane Departure Warning System (LDWS) with Lane-keep Assist System (LAS)</li> <li>Mazda Radar Cruise Control (MRCC) with Stop &amp; Go</li> <li>Blind Spot Monitoring (BSM) with Rear Cross Traffic Alert (RCTA)</li> <li>Smart Brake Support (SBS)</li> <li>Smart City Brake Support Reverse (SCBS-R)</li> <li>Rear Cross-Traffic Braking (RCTB)</li> <li>Rear parking sensors</li> </ul>	<ul style="list-style-type: none"> <li>Blind Spot Assist</li> <li>Front Cross Traffic Alert</li> <li>360-degree View Monitor</li> <li>Front and rear parking sensors</li> <li>Rear-view Camera with Dynamic Lines</li> <li>Driver Monitor (Camera Based)</li> </ul>



## THE MX-30 EV CUSTOMER

Not every buyer will “fit the mold” of MX-30 EV’s target customer perfectly. For any and all customers who show interest in MX-30 EV, there are certain key attributes that you can look for to help identify if MX-30 EV is a good fit for their lifestyle.



Puts a **high priority on emotional attributes** like the driving experience, overall quality and design and craftsmanship.



Drives less than **100 miles a day** with a consistent driving pattern and will use their MX-30 EV **mainly for commuting and daily errands.**

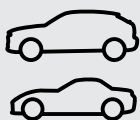

MX-30 EV may be a **secondary vehicle in the household** — an additional gas-powered vehicle may be used for extended driving needs.



Able to **charge their MX-30 EV at home** and enjoys the convenience of not having to visit a gas station.



### MX-30 EV TARGET CUSTOMER

MX-30 EV appeals to customers who want an electric vehicle, but do not want to sacrifice the driving experience, features and value they would expect from a gas-powered vehicle.

- Approximately 25-45 years old
- 60% female
- Single or unmarried couple, with a dog but no children
- Live in a condo in the city

These customers are urban dwellers that love to buy local and from small artisan shops. They enjoy light activities that don't require them to leave the city, such as yoga, running and kickboxing. They are environmentally conscious through small, everyday decisions — such as reusable bags and metal straws — rather than big moves.

## THE RIGHT FIT



Just like sedans and crossovers suit different lifestyles and customer uses, battery-electric vehicles are better suited for certain customers and their needs. The best way to understand whether the electric-vehicle lifestyle is right for your customer is to consult with them on their lifestyle, preferences and overall EV readiness.



Scan this code to access the **Addressing the Range Challenge** video.

Note: you will be directed to an interactive version of Focal Point. Select the menu icon on the top right to navigate to the video.

## EV READINESS: THE NEED-TO-KNOW DETAILS

 <b>RANGE</b> According to AAA, EV owners drive an average of 39 miles per day.	 <b>CHARGING</b> According to J.D. Power, 80% of EV charging is done at home.
<p><b>What does your customer's daily commute look like?</b></p> <ul style="list-style-type: none"> <li>• It is critical that you understand your customer's daily driving habits, typical destinations and round-trip mileage for their commute</li> <li>• Ask questions about your customer's "busiest" day to ensure you've accounted for even their longest driving scenarios</li> </ul>	<p><b>Where does your customer live — in an apartment, condo or single-family home?</b></p> <ul style="list-style-type: none"> <li>• The most convenient way to charge an electric vehicle is at home, so your customer's living situation is a key element of EV readiness</li> <li>• Review EV home-charging options (e.g., Level 1 and Level 2) in the context of your customer's unique living situation</li> </ul>
<p><b>Does your customer frequently go on longer drives — such as road trips?</b></p> <ul style="list-style-type: none"> <li>• In addition to your customer's daily driving habits, you should also understand other scenarios in which range may be a factor</li> <li>• If your customer does like to take longer trips, note that the MX-30 Elite Access Loaner Program may offer the customer the freedom they seek to travel to far-off places from time-to-time</li> </ul>	<p><b>Is your customer open to spending time at public charging stations?</b></p> <ul style="list-style-type: none"> <li>• While electric vehicles are commonly charged at home, knowing that public charging stations are readily available can build confidence in owning an electric vehicle</li> <li>• Customers may not be aware of charging stations in their area. Use the ChargePoint app to explore charging stations near their home/office and build value in their convenient locations</li> </ul>

## ADDRESSING RANGE OBJECTIONS

Some customers may have concerns or questions about MX-30 EV's range. In such cases, it is important to be prepared to have informed conversations about range that build value in Mazda's approach.

1. **Pair the right customer** – During the needs assessment, ensure you're asking the right questions to help identify if MX-30 EV is a good fit. *Visit the [Ultimate Mazda Experience \(UMX\) portal for good Needs Assessment questions.](#)*
2. **Be honest about limitations** – MX-30 EV's range may be shorter, but the smaller battery size comes with significant advantages. Build value in the Mazda-unique design, features, technology and driving experience versus the "battery-on-wheels" approach that some other manufacturers take.
3. **Build confidence in charging infrastructure** – With a variety of home and public charging options readily accessible, a shorter range is not a limitation for everyday driving needs.
4. **Explain the MX-30 Elite Access Loaner Program** – For customers who enjoy occasional road trips, this special perk can help make MX-30 EV's range less of a concern.

### WHAT IF MX-30 EV IS NOT THE RIGHT FIT?

Range is a critical topic for prospective EV buyers, and some may decide that MX-30 EV is not the right fit for them simply due to its range — and that's OK.

- **Don't be discouraged** from selling MX-30 EV. Even if MX-30 EV is not the right fit, demonstrating value in MX-30 EV and Mazda's approach to electrification will ensure customers walk away with a deeper appreciation for Mazda
- **Continue to build a relationship** with your customer. Other vehicles in the Mazda family (now or in the future) may better support their needs and lifestyle



# ENHANCED ULTIMATE MAZDA EXPERIENCE (UMX) STANDARDS

Mazda’s vision for the future is about more than a lineup of electrified vehicles — the customer experience is evolving, too. That’s why enhanced Ultimate Mazda Experience Standards incorporate electric vehicle-specific elements across the customer journey.



## SALES

From Greeting to Follow-up, the Ultimate Mazda Experience Standards help you deliver an exceptional experience for MX-30 EV customers. We have spotlighted one EV-specific touchpoint below — we encourage you to [visit the Ultimate Mazda Experience portal](#) for a full picture of the enhanced EV-specific Sales standards across the customer journey.

### SPOTLIGHT: EV-SPECIFIC VEHICLE DELIVERY

- Make sure the vehicle is fully charged to the recommended 90% at the time of Delivery
- Demonstrate how to use key controls and features, including those specific to the charging process
- Walk through the standard charging process and give the customer a chance to practice to instill confidence
- Set expectations for EV range (e.g., factors that can influence range), charging times and tire wear
- Advise, consult and follow-up on home charger purchase and installation
- If needed, review information that might have been bypassed in pre-Delivery, such as installing apps and setting up accounts, reviewing available incentives and perks and sharing EV-specific resources



*Review the ChargePoint Driver’s Kit with new owners during Delivery to ensure confidence using ChargePoint services.*



## SERVICE

From Appointment to Follow-up, the Ultimate Mazda Experience Standards help you deliver an exceptional experience for MX-30 EV owners. We have spotlighted one EV-specific touchpoint below — we encourage you to [visit the Ultimate Mazda Experience portal](#) for a full picture of the enhanced EV-specific Service standards across the customer journey.

### SPOTLIGHT: EV-SPECIFIC SERVICE RE-DELIVERY

- In addition to usual maintenance items, make note of EV-specific checks that may be less familiar to the customer, such as battery coolant, cabin heater, power inverter and high-voltage wiring
- Review tire tread depth and wear patterns, brake pad thickness and cabin air filter condition
- Set next maintenance appointment and ask permission to contact the customer a week prior to remind them



*Whenever possible, re-deliver the customer’s vehicle with with the maximum recommended State of Charge of 90%.*

## FULL CIRCLE INSPECTION: FOR ELECTRIFIED VEHICLES

During every Service Consultation, Mazda customers are educated on the Full Circle Inspection, including the fact that a Mazda Craftsman (Technician) will perform the inspection, to build value in the process. Now, alongside the MX-30 EV launch, Mazda introduces an enhanced, EV-specific Full Circle Inspection form to help build value in Mazda Service and give customers a reason to continue to choose you for their Service needs.

*Keep your eye out for the enhanced EV-specific Full Circle Inspection form in the coming months.*



# CHARGING 101



While most owners will charge at home overnight, it's easy to charge MX-30 EV both at home or on-the-go. With a charging port conveniently located on the rear passenger side and a portable charging cable included for plugging into any standard 120-volt outlet, MX-30 EV can be charged at the right place, right time and right speed for owners' needs. And, they can check progress via MX-30 EV's in-vehicle display or MyMazda app.



**MAZDA SMART CARDS**  
ELECTRIFICATION BASICS

## CHARGING LEVELS, PORTS & CONNECTORS

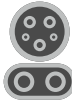
Charging levels are based on the amount of power the source can provide and how quickly each can recharge a vehicle's battery. MX-30 EV's battery can be charged by standard (AC) power at Level 1 and Level 2, or via DC fast charging.

LEVEL 1	LEVEL 2	DC FAST CHARGING	
120V (AC)	208-240V (AC)	440V (DC)	
<ul style="list-style-type: none"> <li>• Common in residential settings</li> <li>• Plug into standard household wall outlet to "trickle charge"</li> </ul>	<ul style="list-style-type: none"> <li>• Home charger can be installed by a professional to fully charge at Level 2 overnight</li> <li>• Also found at public locations such as parking lots/garages, or workplaces</li> </ul>	<ul style="list-style-type: none"> <li>• Only for commercial/public use</li> <li>• Found at public charging locations such as at malls or along highways (usually along with Level 2 chargers)</li> <li>• Cost varies depending on station</li> </ul>	
MX-30 EV charging time is approximately 13 hours and 40 minutes from 20% to 80% charge (at 120 volts of AC current at 15 amps).	MX-30 EV charging time is approximately 2 hours and 50 minutes from 20% to 80% charge (at 240 volts of AC current at 30 amps).	MX-30 EV will charge up to 80% within 36 minutes via DC fast charging (DC max output at 50 kW). <i>Note that MX-30 EV cannot charge at Tesla Supercharging stations.</i>	
<p><b>Level 1 &amp; 2 Connector</b> <i>Compatible with MX-30 EV</i></p>  <p>SAE J1772 (Type 1)</p>		<p><b>DC Connector</b> <i>Compatible with MX-30 EV</i></p>  <p>CCS1 (Combo)</p>	<p><b>Other DC Connector Types</b> <i>Not Compatible with MX-30 EV</i></p>  <p>CHAdeMO</p>  <p>Tesla</p>

## TIPS FOR OPTIMIZING YOUR CHARGE

Aside from keeping MX-30 EV's battery fully charged and planning any charging stops in advance, here are a few simple tips for maximizing everyday driving range:

- **Park in the garage** to minimize effects from extremely hot or cold weather
- **Pre-heat/pre-cool** the cabin via the MyMazda app while charging, or use climate controls sparingly
- **Drive efficiently** by avoiding heavy acceleration and high speeds, which can drain the battery faster
- **Check tire pressure often.** Underinflated tires can negatively impact range



### WHAT HAPPENS IF MX-30 EV RUNS OUT OF A CHARGE ON THE ROAD?

Just like planning a trip to the gas station when the fuel gauge dips toward empty, it's best to keep an eye on MX-30 EV's remaining charge level and head to a charging station when running low. If MX-30 EV's battery does run out of a charge, the vehicle cannot be driven until it is charged again.

Owners should contact Mazda Roadside Assistance via the MyMazda app. If the MX-30 EV must be towed, flatbed towing is recommended to prevent damage to the vehicle.

\*Charging times are estimates and depend on various conditions at the time of charging. See Owner's Manual for details.

# COMPETITIVE COMPARISON

## MAZDA MX-30 EV VS. 2021 NISSAN LEAF S

Touted by Nissan as “the world’s first 100% electric car for the mass market” upon its introduction in 2010, the Nissan LEAF is one of the most well-known all-electric nameplates. Now in its second generation, with greater range and more conventional exterior design, the LEAF is a practical, mainstream option at an affordable starting price.



Note: you will be directed to an interactive version of Focal Point. Select the menu icon on the top right to navigate to the video.



MAZDA MX-30 EV	NISSAN LEAF S
<b>EXTERIOR &amp; PERFORMANCE</b>	
With deeply sculpted headlights and minimalistic grille, MX-30 EV’s front face is purposefully designed to be simple yet powerful, creating an <b>impression of approachability and vitality</b> . And, LED headlights and taillights come standard.	The LEAF’s V-Motion grille features a blue mesh pattern that feels modern and sporty, but its aggressive design <b>lacks the approachability</b> of MX-30 EV’s front face. LED headlights and taillights are not standard equipment on LEAF.
MX-30 EV not only comes equipped with a standard (AC) charging port, but also DC fast-charging capability for quick charge-ups on the go — up to an <b>80% charge within 36 minutes</b> .	The LEAF <b>does not come standard with a DC fast-charging port</b> ; drivers must opt for an optional package or move up to a higher trim for this convenience-enhancing feature.
Even as an all-electric vehicle, MX-30 EV retains Mazda’s signature <b>Jinba-Ittai oneness between car and driver</b> , with crisp steering that responds intuitively to the driver’s intentions and helps create a driving experience of pure joy.	<i>Car &amp; Driver</i> critiques the LEAF for its <b>“snooze-worthy driving dynamics,”</b> while <i>Motor Trend</i> notes that the LEAF feels zippy when merging onto the highway, but the <b>“experience is marred by vague steering.”</b>
MX-30 EV’s cargo area can accommodate four carry-on suitcases. It’s also more user-friendly — the clean, refined design helps facilitate <b>easy loading and unloading</b> of bulky or heavy items without straining.	While the LEAF does offer a generous amount of cargo space, it is not as usable as MX-30 EV. The LEAF’s <b>high liftover causes straining</b> when loading or unloading items.

<b>INTERIOR &amp; PEACE OF MIND</b>	
With a wider range of standard features, MX-30 EV <b>delivers significant value</b> beyond what LEAF has to offer — such as heated front seats, power driver’s seat, power moonroof, Active Driving Display and more.	LEAF may offer a low starting price but it <b>lacks standard features</b> that make an electric-vehicle experience more pleasant or convenient. Features like an Active Driving Display and power moonroof are not available at any trim level.
MX-30 EV’s cabin is designed to create an <b>open and airy ambience</b> that makes the driver feel at ease, with intricate detailing and high-quality, natural materials that add warmth and dimension.	The interior of the LEAF has an economy-car feel, with <b>“an abundance of hard plastics that some might consider disappointing</b> for a \$30,000-plus vehicle,” according to a <i>U.S. News</i> review.
Mazda is dedicated to mastery in even the smallest of details. In MX-30 EV, all buttons feel consistent to the touch when pressed, providing a <b>pleasant sense of harmony</b> throughout the cabin.	When it comes to interior attention to detail, the LEAF’s switches and buttons vary in shape and design, and tactile feedback is inconsistent. According to <i>U.S. News</i> , “some reviewers also say a few of these <b>buttons look “chintzy.”</b> ”
Designed to feel like a gas-powered vehicle, MX-30 EV’s electronic shifter features a <b>simple and familiar shift pattern</b> that is easy to operate and understand.	The LEAF features an <b>unusual and unintuitive joystick-style shifter knob</b> that <i>Edmunds</i> notes as “so odd that it includes its own user diagram.”
MX-30 EV features <b>intuitive steering-wheel paddles</b> that allow drivers to adjust regenerative braking characteristics — all without ever having to take their hands off the wheel or attention off the road.	LEAF drivers must <b>take their hands off the wheel and reach to the center console to operate the e-Pedal switch</b> that toggles between regenerative braking modes.

# COMPETITIVE COMPARISON

## MAZDA MX-30 EV VS. 2021 NISSAN LEAF S

### ADDRESSING NISSAN LEAF ADVANTAGES

In comparison to the Mazda MX-30 EV, the Nissan LEAF has several advantages that may appeal to customers.



LONGER DRIVING RANGE (149 MILES)	OVERALL AFFORDABILITY
<p><b>WHAT TO EXPLAIN:</b> MX-30 EV offers a range that is more than capable of meeting the daily needs of drivers. Plus, MX-30 EV comes standard DC fast-charging ability, while the LEAF S does not. And, MX-30 EV owners are eligible to access the MX-30 Elite Access Loaner Program fleet for 10 calendar days per year — great for longer road trips.</p> <p><b>WHAT TO ASK:</b> What are your daily driving needs?</p> <p><b>WHAT TO DEMONSTRATE:</b> Invite the customer to test drive an MX-30 EV so that they can experience how MX-30 EV retains a strong, emotional connection between vehicle and driver, plus demonstrate how to use the MyMazda app to search for DC charging stations when necessary.</p>	<p><b>WHAT TO EXPLAIN:</b> MX-30 EV delivers significant value with a wider range of standard and available features than LEAF S — all intended to make the driving experience more joyful, even on routine commutes.</p> <p><b>WHAT TO ASK:</b> What features are most important to you?</p> <p><b>WHAT TO DEMONSTRATE:</b> Invite the customer to sit in an MX-30 EV. Highlight the features that are most important to the customer first, while also emphasizing high-value features not available on the LEAF, such as Blind Spot Assist, Active Driving Display and power moonroof.</p>

### IN SUMMARY: CONNECTING THE DOTS

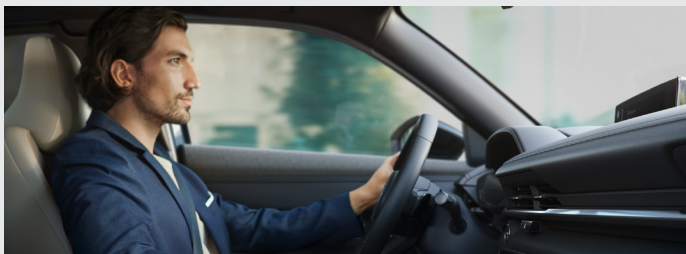

**VALUE** – Although the LEAF boasts a low starting price, MX-30 EV offers more standard features than not only the LEAF, but many electric-vehicle competitors on the market.

**MOTION** – To describe the LEAF driving experience, reviewers use words such as “fine” and “decent.” With MX-30 EV, engineers worked hard to retain Mazda’s characteristically pure and joyful driving experience.

**EMOTION** – The LEAF is a practical mode of transportation, but it does not feel inspired or connected. Inside and out, MX-30 EV is uplifting and engaging, creating an experience that is worth spending time (and money) on.



# COMPETITIVE COMPARISON

## MAZDA MX-30 EV VS. 2022 CHEVROLET BOLT EUV LT

Debuting in 2016, the Chevrolet Bolt EV prioritized efficiency and practicality in an affordable package. However, many customers were left unsatisfied by the plasticky interior, uncomfortable seats and lack of standard features. Now, the new and slightly larger Bolt EUV (“Electric Utility Vehicle”) makes its debut, attempting to address much of what plagued its smaller sibling. Additionally, its compact crossover size makes it a more direct competitor for the MX-30 EV.



Note: you will be directed to an interactive version of Focal Point. Select the menu icon on the top right to navigate to the video.

MAZDA MX-30 EV	CHEVROLET BOLT EUV LT
EXTERIOR & PERFORMANCE	
MX-30 EV’s distinctive exterior styling is meticulously sculpted, designed as a single, solid unit that creates a <b>sense of presence in its simplicity</b> .	<i>Motor1</i> notes that, while Bolt EUV’s “flashier, more modern design” is a step up from the design of the previous Bolt EV, the <b>“proportions are still solidly on the awkward side.”</b>
Mazda places a high value on driving dynamics in all vehicles in the lineup, and MX-30 EV is no exception. This results in MX-30 EV’s <b>engaging, natural driving experience</b> and creates a feeling of pure joy behind the wheel.	Bolt EUV’s handling is described as <b>“competent if not particularly thrilling”</b> ( <i>Car &amp; Driver</i> ). And, road imperfections resulting in “noticeable vibration through the steering column,” according to <i>Road &amp; Track</i> .
Mazda’s approach is holistic. From pedal feel to steering and handling, MX-30 EV upholds Mazda’s <i>Jinba-Ittai</i> philosophy and <b>responds intuitively to the driver’s intentions</b> — MX-30 EV drives and feels like a Mazda.	While complimentary of the driving experience overall, a <i>Cars.com</i> reviewer notes that, like most electric vehicles, the Bolt EUV’s brakes <b>“have very little feel, feedback or linear progression</b> as you approach a full stop.”
MX-30 EV’s cargo area can accommodate four carry-on suitcases. It’s also user-friendly — the clean, refined design helps facilitate <b>easy loading and unloading</b> of bulky or heavy items without straining.	While positioned as a crossover, the Bolt EUV’s dimensions are similar to its hatchback Bolt EV counterpart, resulting in a <b>rather limited cargo area</b> with only two additional cubic feet of real-world space, according to <i>Motor Trend</i> .

INTERIOR & PEACE OF MIND	
Designed with the driver and occupants in mind, MX-30 EV offers a <b>variety of premium amenities and features</b> that make the drive more comfortable and add peace of mind, such as heated front seats, Active Driving Display and a suite of i-Activsense® safety technologies.	With Bolt EUV, <b>many amenities require an upgrade</b> to the higher-price Premier trim or an optional add-on package, such as Blind Spot Monitoring, Rear Cross Traffic Alert and heated front seats. Additionally, features like an Active Driving Display are not available at any Bolt EUV trim.
MX-30 EV’s cabin is designed to create an <b>open and airy ambience</b> that makes the driver feel at ease, with intricate detailing and high-quality, natural and sustainable materials that add warmth and dimension.	<i>U.S. News</i> comments that the Bolt EUV’s cabin materials “look and feel much nicer,” but there are still <b>“flimsy plastics here and there”</b> — a sentiment shared by <i>CNET</i> , which calls out “some of the cheapest-feeling turn signal and wiper stalks.”
True to Mazda’s human-centric design philosophy, MX-30 EV features <b>comfortable, supportive front seats</b> that help promote an ideal driving position — reducing fatigue and delivering a more enjoyable drive experience. Heated seats also come standard on MX-30 EV for optimal comfort.	While noted as an improvement over the previous Bolt EV’s unsupportive and squishy seats, the Bolt EUV’s redesigned <b>seats are “quite hard”</b> with “overly dense cushioning,” according to <i>Edmunds</i> . And, heated seats are only available on the Bolt EUV’s LT trim level as part of an added-cost package.
MX-30 EV boasts a <b>wide range of standard and available driver-assist technologies</b> , all designed to support the driver and increase peace of mind in a variety of real-world scenarios. This includes Mazda Radar Cruise Control with Stop & Go to help facilitate comfortable, safe driving on the highway and in stop-and-go traffic.	One of Bolt EUV’s most compelling selling points is Super Cruise™, Chevy’s semi-autonomous driving technology. However, buyers must upgrade to the pricier Premier trim to even have the option to add it as an extra-cost package. The base LT trim <b>comes standard with cruise control — without stop and go functionality</b> .
To provide better visibility for owners when plugging in to charge in low-light environments or at night, MX-30 EV comes <b>standard with an illuminated charge port</b> and indicator light that displays current charging status.	For Bolt EUV owners, charging up at night may pose a bit more of a challenge — <b>charge-port illumination is treated as an accessory</b> , and not available on the base LT trim. It’s available only on the higher-priced Premier trim (at an added cost).

# COMPETITIVE COMPARISON

## MAZDA MX-30 EV VS. 2022 CHEVROLET BOLT EUV LT

### ADDRESSING CHEVY BOLT EUV ADVANTAGES

In comparison to the Mazda MX-30 EV, the Chevy Bolt EUV has several advantages that may appeal to customers.

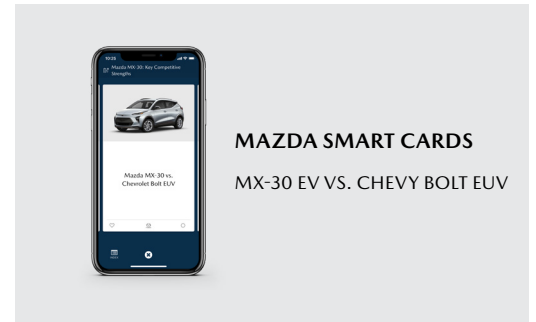

UPGRADED INTERIOR	REAR-SEAT SPACE
<p><b>WHAT TO EXPLAIN:</b> MX-30 EV's warm and inviting interior incorporates sustainable materials while providing high-quality craftsmanship. Technology is integrated seamlessly and designed to be intuitive and human-centric.</p> <p><b>WHAT TO ASK:</b> How much time do you spend in your vehicle?</p> <p><b>WHAT TO DEMONSTRATE:</b> Invite the customer to sit in the driver's seat and demonstrate how intuitive it is to operate the controls. Ask the customer to touch and feel the natural materials throughout the cabin and explain how recycled materials are used to help support sustainability.</p>	<p><b>WHAT TO EXPLAIN:</b> MX-30 EV's freestyle doors help achieve a feeling of openness and freedom. They open wide to enable easy access to the rear seats for passengers and cargo. The rear seats themselves feature the same high-quality craftsmanship and materials as the front.</p> <p><b>WHAT TO ASK:</b> How often will you be transporting rear-seat passengers?</p> <p><b>WHAT TO DEMONSTRATE:</b> Demonstrate how wide MX-30 EV's freestyle doors open to allow easy access to the rear seats. Invite the customer to sit in the backseat to experience the careful attention to detail and craftsmanship.</p>

### IN SUMMARY: CONNECTING THE DOTS



**MOTION** – The Bolt EUV may offer a longer electric range than MX-30 EV, but Mazda designed the MX-30 EV to maintain the great driving dynamics that characterize all Mazda vehicles.



**EMOTION** – The Bolt EUV does feature some nice interior updates and improved materials, but it does not reach the same level of emotional depth, craftsmanship and warmth created by MX-30 EV's natural materials and distinctive design.



**VALUE** – By tweaking the design and size of the original Bolt EV, Chevy offers another practical EV for customers. But, for those seeking more than just a slightly larger commuter EV, MX-30 EV delivers more premium amenities and features as standard — and in a more inspiring package.

# COMPETITIVE COMPARISON

## MAZDA MX-30 EV PREMIUM PLUS VS. 2021 KIA NIRO EV EX PREMIUM

Making its debut for the 2019 model year, the Kia Niro EV is a relatively recent entrant to the electric-vehicle marketplace. With a strong list of features and technology, the Niro EV appeals to shoppers in the market for an entry-level electric vehicle — those looking for more premium or upscale touches need not apply.



Scan this code to access the **MX-30 vs. Kia Niro EV** video.

Note: you will be directed to an interactive version of Focal Point. Select the menu icon on the top right to navigate to the video.

MAZDA MX-30 EV PREMIUM PLUS	KIA NIRO EV EX PREMIUM
<b>EXTERIOR &amp; PERFORMANCE</b>	
MX-30 EV's distinctive exterior styling is meticulously sculpted, designed as a single, solid unit that creates a <b>sense of presence in its simplicity</b> .	The Niro EV features rather standard crossover-like exterior styling that is <b>"neither daring nor inoffensive,"</b> according to <i>The Car Connection</i> .
From steering to braking to acceleration to handling, MX-30 EV delivers the <b>engaging, natural driving dynamics</b> that characterize all Mazda vehicles and create a feeling of joy behind the wheel.	"Not all of our staffers loved the way the Niro EV drives, with some complaining about <b>grinding understeer, unsatisfying brakes and steering, and occasionally jerky acceleration.</b> " – <i>Motor Trend</i>
Even as an all-electric vehicle, MX-30 EV retains Mazda's signature <b>Jinba-Ittai oneness between car and driver</b> , with crisp steering that responds intuitively to the driver's intentions and helps create a driving experience of pure joy.	According to <i>Edmunds</i> , the Niro EV's steering <b>"doesn't translate much feedback from the road,"</b> which can result in a disconnected driving experience that feels numb or muted.
With MX-30 EV, Mazda took a holistic approach focused on offering the appropriate vehicle size in the segment, equipped with the <b>appropriate battery size to meet daily driving needs</b> , offer a shorter time to charge and reduce environmental impact.	The Niro EV's battery pack weighs almost 385 pounds more than MX-30's battery pack (1,008 lbs. vs. 683.4 lbs.), contributing to its <b>less-than-nimble driving character</b> that can "bounce and bound and feel a half-step behind on quick changes in direction," according to <i>The Car Connection</i> .

<b>INTERIOR &amp; PEACE OF MIND</b>	
MX-30 EV's cabin is designed to create an <b>open and airy ambience</b> that makes the driver feel at ease, with intricate detailing and high-quality, natural materials that add warmth and dimension.	In contrast to the MX-30 EV's well-crafted interior, the Niro EV lacks warmth, with <b>"large sections of soulless black plastic"</b> throughout the interior that "isn't pleasant to look at or touch," according to <i>Car &amp; Driver</i> .
From the Mazda Connect™ display positioned high on the dashboard, to the new climate controls with audible feedback and buttons around the bezel, MX-30 EV's interior is human centric and <b>designed to minimize distraction from road</b> .	The Niro EV does boast an available 10.3-inch touchscreen infotainment display integrated cleanly into the dashboard, but the <b>excess of digital gauges, menus, buttons, dials and switches</b> make the cockpit feel busy and overwhelming.
In addition to excellent overall visibility, MX-30 EV's <b>modern interpretation of crossover design</b> creates new value through wide-opening freestyle doors, a floating console with extra room for storage and a thoughtful cargo area.	While Niro EV does offer an elevated seating position and clear visibility characteristic of a crossover, it does not deviate from a conventional approach — the resulting design feels capable, but <b>uninspiring and bland</b> .
Mazda's safety philosophy places high respect on a driver's abilities and offers technologies that <b>support the driver in driving safely</b> . For example, MX-30 EV's enhanced i-Activsense® features, such as Blind Spot Assist, help provide subtle steering assist only when necessary.	While the Niro EV does offer a long list of safety features, <i>Edmunds</i> reviewers "found the <b>lane keeping assist to be too aggressive</b> , constantly fighting your hands to make minor corrections" — which contrasts directly with Mazda's philosophy of supporting (not replacing) the driver.
MX-30 EV's 12-speaker Bose® Premium Audio system features a speaker layout designed to deliver <b>powerful, clear and natural surround sound for all occupants</b> .	The Niro EV <b>tops out at an 8-speaker Harman Kardon system</b> — four speakers less than MX-30 EV's 12-speaker Bose® Premium Audio system.



# COMPETITIVE COMPARISON

## MAZDA MX-30 EV PREMIUM PLUS VS. 2021 KIA NIRO EV EX PREMIUM

### ADDRESSING KIA NIRO EV ADVANTAGES

In comparison to the Mazda MX-30 EV, the Kia Niro EV has several advantages that may appeal to customers.

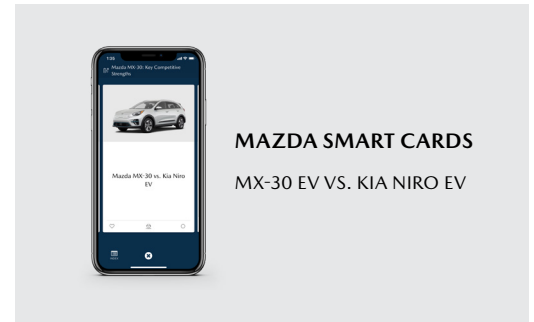

BATTERY SIZE & RANGE (239 MILES)	OVERALL FEATURES & VALUE
<p><b>WHAT TO EXPLAIN:</b> MX-30 EV's battery size was intentional. The battery is the appropriate size to meet typical daily driving needs, offer a shorter time to full charge and reduce CO<sub>2</sub> emissions over the entire vehicle lifecycle.</p> <p><b>WHAT TO ASK:</b> What do your day-to-day drives look like?</p> <p><b>WHAT TO DEMONSTRATE:</b> Invite the customer to test drive MX-30 EV and point out MX-30 EV's nimble handling and engaging driving dynamics. Also, underscore the advantages of MX-30 EV's appropriately sized battery.</p>	<p><b>WHAT TO EXPLAIN:</b> Even at its lower starting price, MX-30 EV offers features that are not available on Niro EV, such as a power driver's seat or Active Driving Display. Additionally, MX-30 EV's elevated level of design and craftsmanship delivers true emotional value.</p> <p><b>WHAT TO ASK:</b> What features do you use most often?</p> <p><b>WHAT TO DEMONSTRATE:</b> Showcase high-value features to the customer during the vehicle presentation or test drive. Invite the customer to touch and feel the high-quality interior materials and share craftsmanship stories to build an emotional connection.</p>

### IN SUMMARY: CONNECTING THE DOTS



**VALUE** – While the Niro EV does come equipped with a wide variety of features, its price point is not as affordable as one might expect. MX-30 EV offers a better value proposition, with sought-after features at a lower starting price — many, like an Active Driving Display and 360-degree View Monitor, are not even available on Niro EV at all.

**MOTION** – Although the Niro EV delivers a longer driving range, the driving experience itself is “unsatisfying” and lacks refinement according to some reviewers. Mazda designs cars that are engaging, dynamic and enjoyable to drive, with an appropriate range that meets the daily needs of drivers.

**EMOTION** – The Niro EV can be considered a practical choice with added flair from its futuristic design elements and ambient lighting, but MX-30 EV transcends mass-market design with its Human Modern design, high-quality craftsmanship and natural, sustainable materials.

# COMPETITIVE COMPARISON

## MAZDA MX-30 EV PREMIUM PLUS VS. 2021 TESLA MODEL 3 STANDARD RANGE PLUS

A juggernaut in the electric-vehicle market since its introduction in 2017, the Tesla Model 3 upholds Tesla's brand reputation for innovative, future-forward technology. Boasting a generous driving range and an impressive 0-60 figure, the Model 3 is an appealing option for those looking for a Tesla experience at a slightly more accessible price.



Scan this code to access the **MX-30 vs. Tesla Model 3** video.

Note: you will be directed to an interactive version of Focal Point. Select the menu icon on the top right to navigate to the video.

MAZDA MX-30 EV PREMIUM PLUS	TESLA MODEL 3 STANDARD RANGE PLUS
EXTERIOR & PERFORMANCE	
MX-30 EV's distinctly Mazda exterior design offers unique appeal by maintaining a <b>sense of familiarity</b> , while also feeling inviting to drive.	The Model 3's exterior styling is unmistakable but feels <b>pod-like and futuristic</b> — a look that could alienate those looking to make less of a future-forward statement.
For Mazda, a truly joyful driving experience is about more than just off-the-line specs. From e-Skyactiv® to e-GVC Plus, Mazda worked hard to foster a <b>natural, engaging driving experience</b> in MX-30 EV, mirroring the familiar feel of a gas-powered vehicle.	Powerful acceleration is a selling point for Model 3 — however, the Model 3's <b>acceleration is dependent on the level of charge</b> . Less torque is available if the battery is at a low level of charge, which can be frustrating or dangerous for drivers.
MX-30 EV is designed to deliver unique value for drivers by retaining Mazda's <b>signature Jinba-Ittai connection</b> — a connection strengthened by MX-30's EV enhanced i-Activsense® technologies that support, but never replace, the driver.	The Model 3's Autopilot advanced safety and convenience technology may be cool, but ultimately <b>takes control away from the driver</b> and nearly eliminates the connection between the driver and the road.
MX-30 EV's drive experience is <b>quiet and comfortable</b> , with a cabin environment that settles the mind. Additionally, MX-30 EV features unique EV sounds designed with chords that are pleasant to the human ear, creating a deeper connection between car and driver.	Due in part to its silent operation and lack of sound-deadening measures, the Model 3 suffers from <b>prominent road and tire noise</b> , with <i>Car &amp; Driver</i> noting that "the tires thwack and thrum over pavement imperfections."

INTERIOR & PEACE OF MIND	
MX-30 EV's cabin is designed to create not only an <b>open and airy ambience, but also a sense of comfort</b> — settling the mind and creating a feeling of serenity.	The Model 3's minimalistic cabin may feel space-age and high-tech, but it offers drivers and passengers <b>little warmth or comfort</b> for their drive.
The fit and finish throughout MX-30 EV's interior is exquisite, featuring <b>high-quality, natural materials</b> , such as the use of Heritage Cork and recycled materials, that add warmth and dimension.	A majority of reviewers note that the Model 3's <b>materials and build quality are disappointing</b> , with <i>The Car Connection</i> stating that "the fabrics, panels, trims, and everything in between have felt cheap and under-detailed ..."
All displays in MX-30 EV are <b>designed to minimize driver distraction</b> . For example, MX-30 EV's touchscreen climate controls are intuitive, offering simple operation, audible feedback and functional buttons to maximize focus on the road.	While the large, tablet-like touchscreen delivers a "wow" factor, its numerous functions and submenus <b>force drivers to look away from the road</b> to complete even routine tasks — which can prove distracting, especially when in motion.
MX-30 EV's electronic shifter features a <b>simple and familiar shift pattern</b> that is easy to operate and understand. In fact, the entire MX-30 EV experience is designed to be intuitive and familiar for drivers, even if they have never driven an electric vehicle before.	Model 3 forgoes nearly all familiar buttons, dials and levers, so drivers <b>must "re-learn" how to operate a car</b> . For example, Model 3's shift lever functions much like a windshield-wiper stalk and often requires visual confirmation that the correct gear is selected, and the speedometer is on the center display.
MX-30 EV's unique freestyle doors open wide to reveal <b>rear seats that envelop passengers in comfort</b> , ensuring that time spent with MX-30 EV is enjoyable for passengers, too.	According to <i>Car &amp; Driver</i> , the Model 3's <b>rear seats are "cramped and uncomfortable,"</b> while <i>Kelley Blue Book</i> notes that the low seat cushions "have taller passengers sitting with their knees higher than their hips."

# COMPETITIVE COMPARISON

## MAZDA MX-30 EV PREMIUM PLUS VS. 2021 TESLA MODEL 3 STANDARD RANGE PLUS

### ADDRESSING TESLA MODEL 3 ADVANTAGES

In comparison to the Mazda MX-30 EV, the Tesla Model 3 has several advantages that may appeal to customers.

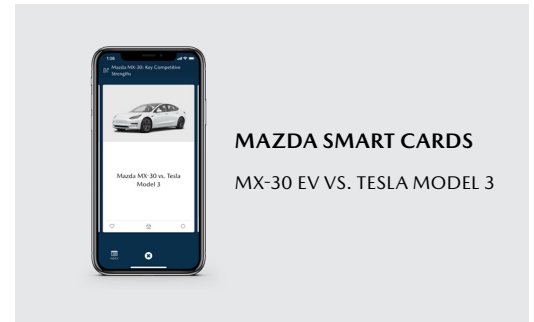

TESLA CHARGING INFRASTRUCTURE	HIGH-TECH INTERIOR
<p><b>WHAT TO EXPLAIN:</b> If you choose to charge while on-the-go, MX-30 EV offers both standard AC and DC fast-charging capability, so you can select from a wide variety of charging locations, including those in the ChargePoint network, at your convenience. At Tesla Supercharging stations, you may find lengthy wait times and crowded stalls.</p> <p><b>WHAT TO ASK:</b> Where do you think you will charge your vehicle most often — at home or on the road?</p> <p><b>WHAT TO DEMONSTRATE:</b> Show the customer MX-30 EV’s charging port location and explain the time for both standard (AC) and DC fast-charging options. Demonstrate how the MyMazda app makes it easy to locate charging stations.</p>	<p><b>WHAT TO EXPLAIN:</b> Mazda believes that technology should be designed to make driving more enjoyable, and not detract from an emotional connection to the road. Interacting with MX-30 EV is intuitive and familiar, so you are able to acclimate quickly behind the wheel — it does not feel like you have to “re-learn” how to drive a car.</p> <p><b>WHAT TO ASK:</b> How familiar are you with driving an electric vehicle?</p> <p><b>WHAT TO DEMONSTRATE:</b> Demonstrate how intuitive it is to operate MX-30 EV’s features, like the electronic shifter. Highlight interior elements that create warmth and an emotional bond, such as the Heritage Cork.</p>

### IN SUMMARY: CONNECTING THE DOTS



**MOTION** – With its quick acceleration, the Model 3’s performance attributes are formidable. However, it does not feel like a “driver’s car.” In fact, Tesla deliberately omits the driver. In contrast, Mazda deliberately enhances the experience for the driver.

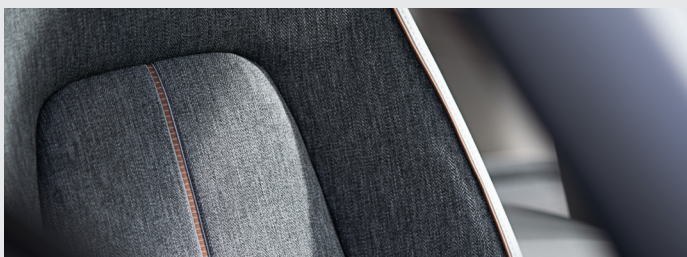

**EMOTION** – The Model 3 may be innovative, but it lacks heart and soul — especially on the interior, where drivers spend the most time. MX-30 EV’s cabin is warm and finely crafted, designed to settle the mind and make time spent behind the wheel worthwhile.



**VALUE** – The Model 3 starts at a higher price point than MX-30 EV, and some of Tesla’s more advanced features, like the full self-driving capability, are not available without a costly upgrade.



# COMPETITIVE COMPARISON

## MAZDA MX-30 EV PREMIUM PLUS VS. 2022 MINI COOPER SE ICONIC

Debuting in 2020, the all-electric MINI Cooper SE retains the spunky spirit of its gas-powered MINI counterpart, boasting a fun-to-drive ethos and highly customizable colors and options. While not the most functional option, the MINI Cooper SE appeals to drivers who don't mind sacrificing everyday practicality for the all-electric MINI brand experience.



Scan this code to access the **MX-30 vs. MINI Cooper SE** video.

Note: you will be directed to an interactive version of Focal Point. Select the menu icon on the top right to navigate to the video.

MAZDA MX-30 EV PREMIUM PLUS	MINI COOPER SE ICONIC
<b>EXTERIOR &amp; PERFORMANCE</b>	
MX-30 EV's distinctive exterior styling is meticulously sculpted, designed as a single, solid unit that creates a <b>sense of presence in its simplicity</b> .	The MINI Cooper SE flaunts its hot-hatch exterior styling, but the "travel pod" (Car & Driver) look, Union Jack taillights and yellow accents may feel <b>too flashy or conspicuous</b> .
MX-30 EV <b>delivers a driving range that easily meets the day-to-day driving needs of drivers</b> . Plus, MX-30 EV translates Mazda's effortless, joyful driving experience to an electric vehicle.	The MINI Cooper SE has an electric range that's ideal for most around-the-city driving. However, <i>Motor Trend</i> notes that if the shorter range isn't a dealbreaker, "the driving experience might be," and that " <b>enthusiastic driving is met with resistance</b> ."
Even as an all-electric vehicle, MX-30 EV retains Mazda's signature <b>Jinba-Ittai oneness between car and driver</b> , with crisp steering that responds intuitively to the driver's intentions and helps create a driving experience of pure joy.	The MINI Cooper SE boasts peppy, go-kart handling but, according to <i>Motor Trend</i> , <b>ride quality is firm</b> and "all but the smoothest of roads will have your head bobbing and stomach jiggling."
MX-30 EV's <b>thoughtful cargo area</b> features a clean, refined design that makes loading and unloading of items easy. If extra cargo space is needed, MX-30 EV's freestyle doors open wide to facilitate easy access to the rear seats.	With its two-door style and limited cargo capacity, the MINI Cooper SE is <b>not as practical or comfortable for everyday life</b> — a contrast to MX-30 EV with its freestyle doors and ample cargo space.

<b>INTERIOR &amp; PEACE OF MIND</b>	
MX-30 EV's cabin fuses style, function and heritage by incorporating <b>natural, Mazda-unique materials</b> — such as the Heritage Cork interior accents that represent Mazda's origins as a cork manufacturer in Hiroshima.	The MINI Cooper SE features a quirky interior that may be polarizing for some drivers. Additionally, <i>U.S. News</i> notes that some of the interior components were "clearly designed with form rather than function in mind," making them <b>less intuitive to use</b> .
MX-30 EV's <b>intuitive Mazda Connect™ infotainment system</b> is designed to be referenced at-a-glance, minimizing distraction from the road. Apple CarPlay® and Android Auto™ also come standard.	The MINI Cooper SE's infotainment display is housed in a circular hub out of the driver's direct line of sight. It also <b>does not offer Android Auto™</b> compatibility for Android™ users.
MX-30 EV's unique freestyle doors open wide to reveal <b>rear seats that envelop passengers in comfort</b> , ensuring that time spent with MX-30 EV is enjoyable for passengers, too.	The MINI Cooper SE can seat up to four, but <b>rear-seat passengers won't ride in comfort</b> — both <i>Motor Trend</i> and <i>U.S. News</i> call the rear seats "cramped."
MX-30 EV offers a variety of <b>thought-out storage options</b> integrated seamlessly into the interior design, including a unique cut-out section underneath the floating center console, two deep cupholders and ample door pockets.	Inside the MINI Cooper SE's cabin, <b>storage and cupholder options are limited</b> with the door pockets "too narrow to even accommodate a small bottle," according to Edmunds.
MX-30 EV offers a <b>wide range of advanced i-Activsense® safety and driver-assist features</b> for added peace of mind, including enhanced features such as Blind Spot Assist and Front Cross Traffic Alert.	The MINI Cooper SE's <b>safety and driver-assist offerings are lacking</b> — even familiar features like adaptive cruise control, lane-keep assist, blind-spot monitoring and rear cross-traffic alert are notably absent or optional.

# COMPETITIVE COMPARISON

## MAZDA MX-30 EV PREMIUM PLUS VS. 2022 MINI COOPER SE ICONIC

### ADDRESSING MINI COOPER SE ADVANTAGES

In comparison to the Mazda MX-30 EV, the MINI Cooper SE has several advantages that may appeal to customers.

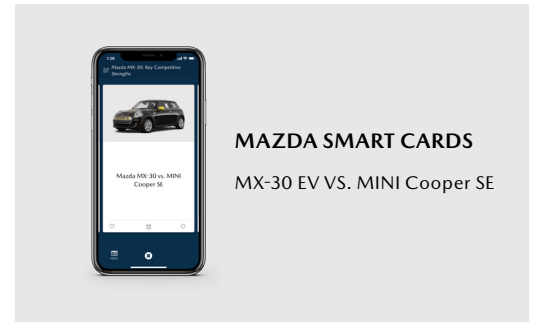

FUN & FUNKY PERSONALITY	SMALL & MANEUVERABLE SIZE
<p><b>WHAT TO EXPLAIN:</b> MX-30 EV's accents speak to Mazda's brand heritage, including the use of Heritage Cork. MX-30 EV's interior feels premium and dimensional but does not sacrifice everyday practicality. Everything is purposeful and designed around the driver.</p> <p><b>WHAT TO ASK:</b> How do you plan on using your vehicle in your day-to-day life?</p> <p><b>WHAT TO DEMONSTRATE:</b> Showcase the balance of heritage and practicality — invite the customer to open the freestyle doors and experience the ease of entry. Highlight the Heritage Cork and explain the historical relevance.</p>	<p><b>WHAT TO EXPLAIN:</b> MX-30 EV offers a tight turning circle for city maneuverability and a more commanding view of the road. Plus, features such as the 360-degree View Monitor and Rear Cross Traffic Alert help support the driver.</p> <p><b>WHAT TO ASK:</b> Will you be doing much city driving?</p> <p><b>WHAT TO DEMONSTRATE:</b> Invite the customer to test drive the MX-30 EV. Highlight the excellent visibility and high seating position, plus the tight turning circle. Showcase the 360-degree View Monitor and other features that make it easy to maneuver the MX-30 EV.</p>

### IN SUMMARY: CONNECTING THE DOTS



**EMOTION** – While the MINI Cooper SE has emotion, spirit and heritage built in, so does MX-30 EV. Inside and out, MX-30 EV fuses style, craftsmanship and heritage without feeling flashy or over-the-top.



**VALUE** – MINI Cooper SE boasts an affordable price. However, MX-30 EV's wide array of standard and available features and technology offer added value for Mazda customers.



**MOTION** – MINI has a reputation for being fun to drive, but reviewers note that the MINI Cooper SE's performance is "gutless." MX-30 EV is distinctly a Mazda, maintaining the engaging driving dynamics and handling that the Mazda brand is known for.

# COMPETITIVE COMPARISON

## MAZDA MX-30 EV VS. THE COMPETITION

	Mazda MX-30 EV	21MY Nissan LEAF S	22MY Chevy Bolt EUV LT	Mazda MX-30 EV Premium Plus	20MY Kia Niro EV EX Premium	21MY Tesla Model 3 SR+	22MY MINI Cooper SE Iconic
<div style="display: flex; align-items: center;"> <div style="width: 20px; height: 20px; background-color: #cccccc; margin-right: 5px;"></div> <span>= COMPETITIVE ADVANTAGE</span> </div>							
<b>PRICE/COST OF OWNERSHIP</b>							
MSRP	\$33,470	\$31,600	\$33,000	\$36,480	\$44,590	\$39,990	\$36,900
Federal Rebate <small>*Rebates subject to change. Check ChargePoint for latest.</small>	\$7,500	\$7,500	N/A	\$7,500	\$7,500	N/A	\$7,500
Range (Miles)	100*	149	247	100*	239	263	114
EV Component/Battery Warranty	TBA	8 Years/100,000 miles	8 Years/100,000 miles	TBA	10 Years/100,000 miles	8 Years/100,000 miles	8 Years/100,000 miles
Battery Capacity	35.5 kWh	40 kWh	65 kWh	35.5 kWh	64 kWh	50-55 kWh (est)**	32.6 kWh
<b>PERFORMANCE</b>							
Horsepower	143 hp	147 hp	200 hp	144 hp	201 hp	283 hp (est)**	184 hp
Torque	200 lb-ft	236 lb-ft	266 lb-ft	200 lb-ft	291 lb-ft	307 lb-ft (est)**	270 lb-ft
Drivetrain	FWD	FWD	FWD	FWD	FWD	RWD	FWD
DC Fast Charging Port	STD	OPT	STD	STD	STD	Supercharger	STD
<b>SAFETY &amp; TECHNOLOGY</b>							
Front Cross Traffic Alert	N/A	N/A	N/A	STD	N/A	OPT	N/A
Blind Spot Assist	N/A	STD	N/A	STD	N/A	OPT	N/A
Driver Monitor	N/A	N/A	N/A	STD	N/A	STD	N/A
Smart City Brake Support Reverse	STD	STD	N/A	STD	N/A	N/A	N/A
Rear Cross Traffic Braking	STD	N/A	N/A	STD	N/A	N/A	N/A
Top View Monitor	N/A	N/A	N/A	STD	N/A	N/A	N/A
Active Driving Display	STD	N/A	N/A	STD	N/A	N/A	STD
Driver Attention Alert	STD	N/A	N/A	STD	STD	N/A	N/A
Radar Cruise Control with Stop & Go	STD	w/o Stop & Go	w/o Stop & Go	STD	STD	STD	STD
Lane Departure Warning	STD	STD	STD	STD	STD	STD	STD
Lane Keep Assist	STD	STD	STD	STD	STD	STD	N/A
Blind Spot Monitoring	STD	STD	OPT	STD	STD	STD	N/A
Rear Cross Traffic Alert	STD	STD	OPT	STD	STD	N/A	N/A
Adaptive Front Lighting System	STD	N/A	N/A	STD	N/A	N/A	N/A
LED Headlights	STD	N/A	STD	STD	N/A	STD	STD
High Beam Control	STD	STD	STD	STD	N/A	STD	N/A
LED Taillights	STD	N/A	STD	STD	STD	STD	STD
Connected Services	STD	STD	STD	STD	STD	STD	STD
<b>CONTENT</b>							
Alloy Wheels	18"	16"	17"	18"	17"	18"	17"
Heated Front Seats	STD	N/A	OPT	STD	STD	STD	STD
Power Driver's Seat	8-way w/ memory	N/A	OPT	8-way w/ memory	10-way w/2-way power lumbar	12-way	N/A
Moonroof	STD	N/A	N/A	STD	STD	Glass Roof	STD
Audio System	8-speaker	4-speaker	6-speaker	12-speaker Bose®	8-speaker	7-speaker	6-speaker
Heated Steering Wheel	N/A	N/A	OPT	STD	STD	N/A	STD

\*EPA Estimated Range

\*\*Based on third-party sources